

Characteristics

Characteristics	Symbol	Unit	Description
General Features			
Type			Compact cylinder
Series			NZ7, NZ8, NZ6
Series			Piston rod cylinder
NZ7..., NZ8...			Single acting without cushioning
NZ6...			Double acting without cushioning
NZD6...			With through piston rod Double acting without cushioning
NZV6...			Non-rotating Double acting without cushioning
NZVD6...			Non-rotating, double acting without cushioning and with through piston rod
Mounting			See drawing
Tube connection			Thread
Ambient temperature range	T_{min} T_{max}	°C °C	-20 +80
Medium temperature range	T_{max}	°C	+80
Weight (mass)		kg	See table
Installation			In any position
Medium			Filtered and lubricated or filtered and unlubricated compressed air
Lubrication			Oil mist lubrication compatible with polyurethane
Material			
Cylinder tube			Aluminium, anodised
Front/Rear end caps			Aluminium
Piston rod			Steel, high-alloy
Pneumatic Characteristics			
Nominal pressure	p_n	bar	6
Operating pressure	p_{min} p_{max}	bar bar	0,5 (1,0 Single acting version) 10
Piston diameter		mm	32 40 50 63 80 100
Port size			G1/8 G1/8 G1/8 G1/8 G1/8 G1/8
Piston rod diameter		mm	12 16 20 20 25 25
Piston rod thread			
Internal			M8 M8 M10 M10 M12 M12
External			M10 M10 M12 M12 M16 M16 x1.25 x1.25 x1.25 x1.25 x1.5 x1.5
Stroke length		mm	Standard stroke length see order instructions
Piston force and air consumption			See page 9
Cushioning		mm	Elastomer cushioning at both ends
Spring return force max.		N	See diagram

Compact Cylinder Ø 32-100 mm

Compact cylinder
to ISO 21287

Series NZ....

Series NZD....

Series NZV....

Series NZVD....

Versions:

- single acting
- double acting without cushioning
- for contactless position sensing
- with through piston rod
- non-rotating
- option of internal or external mounting on piston rod
- ATEX-Version 

Special versions:

- Viton version for high temperature range (+150°)
- various piston rod extensions
- various piston rod materials
- with adaptor plate for valve mounting

The cylinder profile has grooves in which, depending on stroke length, one or more magnetic switches can be mounted for sensing the end positions or intermediate positions of the magnetic piston.

The delivery includes:

- 1 Cylinder
- 1 Hexagon nut for piston rod thread

Magnetic switches are not included - please order these separately



Profile for Basic Cylinder NZ

Ø32 mm, Ø40 mm



Ø50 mm, Ø63 mm



Ø80 mm, Ø100 mm

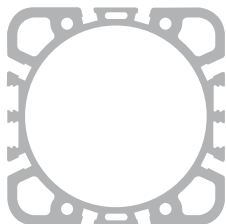

Weight (mass) kg

Cylinder version	Cylinder diameter											
	Ø32		Ø40		Ø50		Ø63		Ø80		Ø100	
	1*	2*	1*	2*	1*	2*	1*	2*	1*	2*	1*	2*
Standard Type NZ	0.293	0.036	0.417	0.051	0.573	0.071	0.826	0.081	1.272	0.104	2.209	0.128
With through rod piston Type NZD	0.313	0.045	0.453	0.066	0.635	0.095	0.872	0.105	1.371	0.142	2.337	0.161
Non-rotating Type NZV	0.395	0.044	0.543	0.059	0.778	0.083	1.093	0.093	1.738	0.122	2.843	0.148
Non-rotating, with through rod piston Type NZVD	0.517	0.061	0.705	0.082	1.046	0.120	1.404	0.130	2.303	0.178	3.605	0.198

* 1 = Cylinder weight (10 mm stroke)
2 = Weight per further 10 mm stroke length

Mounting	Cylinder diameter					
	Ø32	Ø40	Ø50	Ø63	Ø80	Ø100
A	0.146	0.186	0.335	0.390	0.789	1.003
B	0.072	0.093	0.166	0.221	0.487	0.741
BA	0.100	0.128	0.205	0.303	0.568	0.905
BAS	0.106	0.146	0.216	0.322	0.561	0.864
C	0.095	0.115	0.229	0.277	0.623	0.780
D	0.095	0.115	0.229	0.277	0.623	0.780
Security bolt for mounting B,BA,BAS	0.034	0.055	0.062	0.127	0.160	0.315

Dimensions (mm) for Special Piston Rod Threads and Thread length

Piston Rod with External Thread (mm)			
Cylinder-Ø	Special Thread KK	Standard Thread KK	SW
32	M10	M10x1.25	10
40	M10	M10x1.25	13
50	M12	M12x1.25	17
63	M12	M12x1.25	17
80	M16	M16x1.5	19
100	M16	M16x1.5	22
External Thread Length of the Piston Rod (mm)			
Cylinder-Ø	A _{min.}	A _{Standard}	A _{max.}
32	13	19	99
40	13	19	99
50	13	22	99
63	13	22	99
80	13	28	99
100	13	28	99

Note:

In the configuration of a cylinder with through piston rod, Series NZD, the assumption is that both piston rods are identical. Only one is configured and this applies to both piston rods. If two different piston rods are required, a special cylinder must be ordered. Special cylinders are not configurable.

**Theoretical Spring Return Forces in relation to Stroke Length
Series NZ7000, NZ8000**

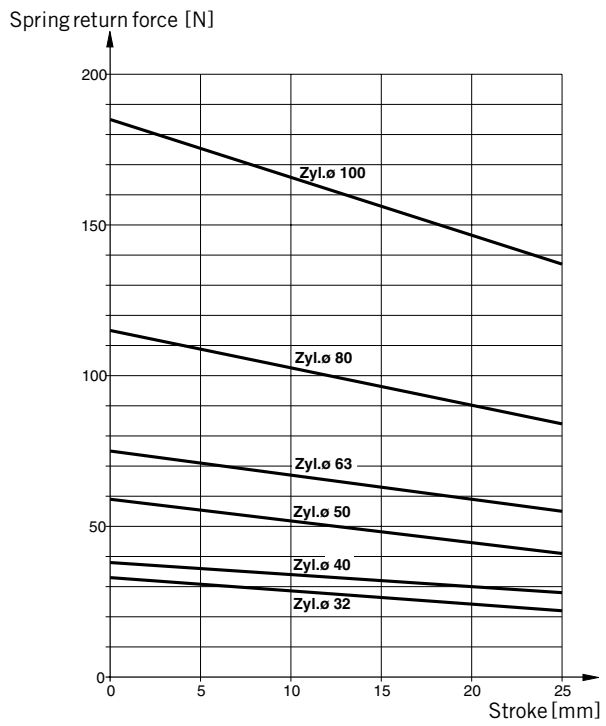

Piston force and air consumption see page 9, dimensions see page 36-41, order instructions see page 42, 43

Dimensions – Basic Cylinder, Ø 32 – 100 mm
Version: Piston rod with Internal Thread (Series NZ..../...)

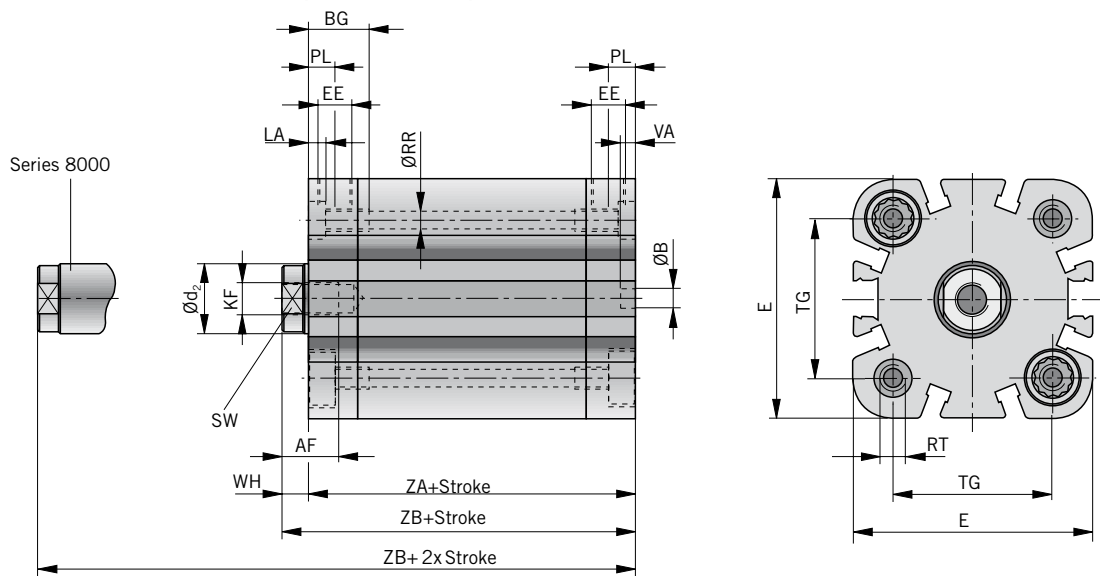

Dimensions – Basic Cylinder, Ø 32 – 100 mm
Version: Piston rod with External Thread (Series NZ..../...-AG)

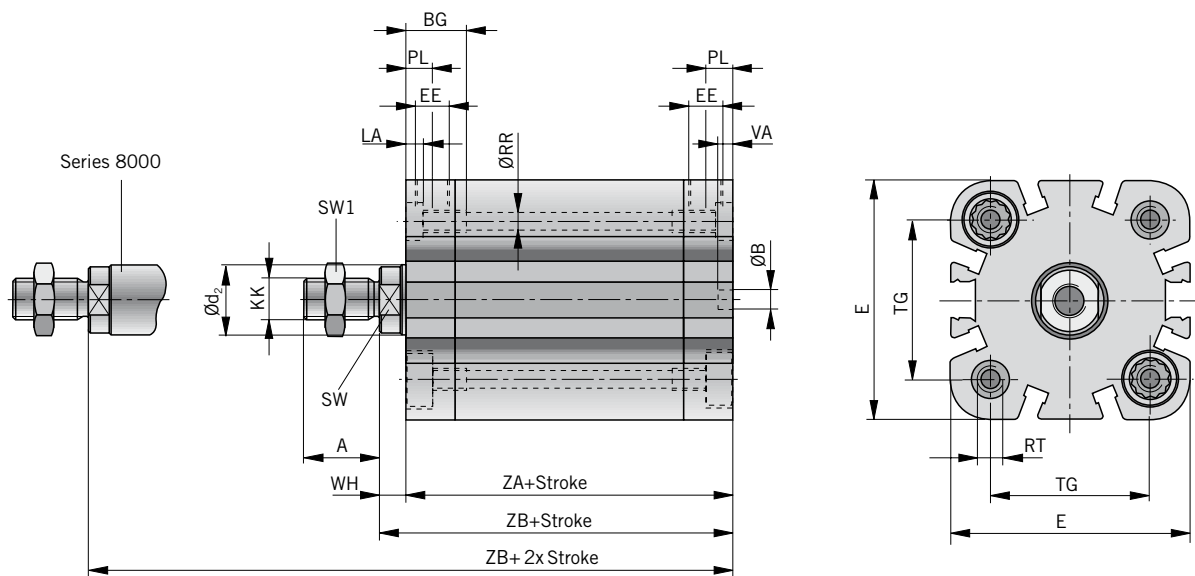

Dimension Table (mm) – Series NZ...., NZD...

Cyl. Ø	A	ØB ^{H9}	Ød ₂ _{n9}	E	AF	BG	EE	KF	KK
32	19	6	12	50	13	14.5	G1/8	M8	M10x1.25
40	19	6	16	58	13	14.5	G1/8	M8	M10x1.25
50	22	6	20	70	16	14	G1/8	M10	M12x1.25
63	22	8	20	80	16	14.5	G1/8	M10	M12x1.25
80	28	8	25	96	20	15.5	G1/8	M12	M16x1.5
100	28	8	25	116	20	20	G1/8	M12	M16x1.5

Piston force and air consumption see page 9, order instructions see page 42, 43

Dimensions – Basic Cylinder with Through Piston Rod, Ø 32 – 100 mm
Version: Piston rod with Internal Thread (Series NZ.../...)

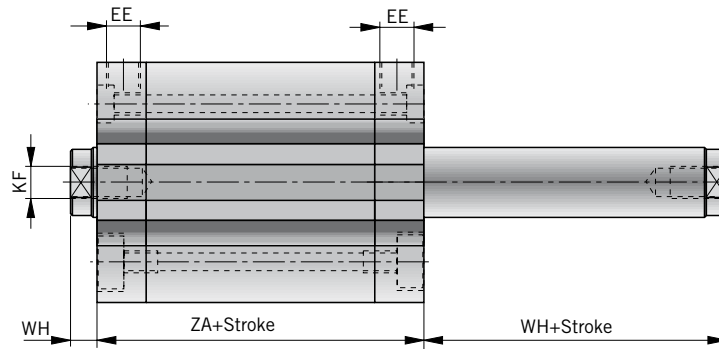

Dimensions – Basic Cylinder with Through Piston Rod, Ø 32 – 100 mm
Version: Piston rod with External Thread (Series NZ.../...-AG)

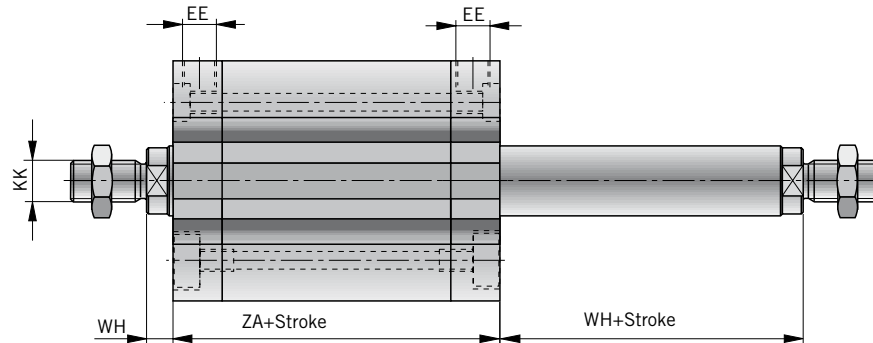

Cyl. Ø	LA	PL	TG	ØRR	RT	SW	SW1	VA	WH	WH+Stroke	ZA+Stroke	ZB+Stroke (*)
32	5	7.5	32.5	8.5	M6	10	17	4	7	7	44	51
40	5	7.5	38	8.5	M6	13	17	4	7	7	45	52
50	6	7.5	46.5	10.5	M8	17	19	4	8	8	45	53
63	6	7.5	56.5	10.5	M8	17	19	4	8	8	49	57
80	2	7.5	72	13.8	M10	19	24	4	10	10	54	64
100	2	10	89	13.8	M10	22	24	4	10	10	67	77

(* for Series NZ8000: ZB+2xStroke)

Mountings – Series NZ..., Ø 32 – 100 mm

Dimensions for Mounting A

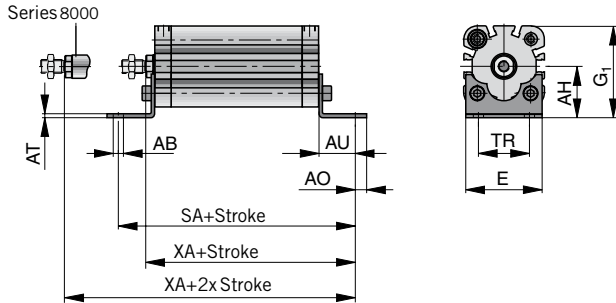

Material: steel, passivated

Dimension Table (mm) – Mounting A

Cyl. Ø	E	G ₁	ØAB	AH	AO	AT	AU	SA +Stroke	TR	XA +Stroke (*)
32	47	57	7	32	8	4	24	92	32	75
40	53	65	10	36	10	4	28	101	36	80
50	65	80	10	45	10	5	32	109	45	85
63	75	90	10	50	10	5	32	113	50	89
80	95	111	12	63	14	6	41	136	63	105
100	115	129	14.5	71	15	6	41	149	75	118

Included in delivery: 2 foot brackets, 4 screws
 (*) Series NZ8000: XA + 2x Stroke

Dimensions for Mounting BA

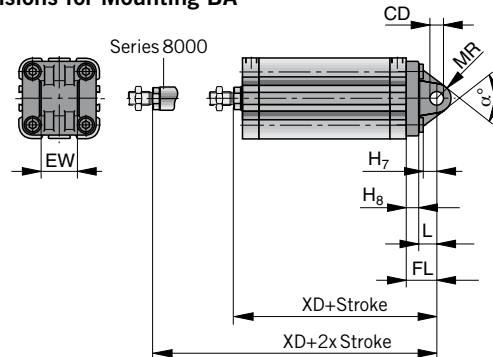

Material: cast aluminium

Dimension Table (mm) – Mounting BA

Cyl. Ø	H ₇	H ₈	L	ØCD ^{H8}	EW	FL	MR	XD +Stroke (*)	α°
32	10	10	12	10	26	22	10.5	73	60
40	13	10	15	12	28	25	13	77	60
50	12	11	16	12	32	27	13	80	70
63	17	11	21	16	40	32	17	89	60
80	16	15	21	16	50	36	17	100	70
100	20.5	16	25	20	60	41	21	118	70

Included in delivery: 1 rear trunnion mounting, 4 screws
 (*) Series NZ8000: XD + 2x Stroke

Dimensions for Mounting B

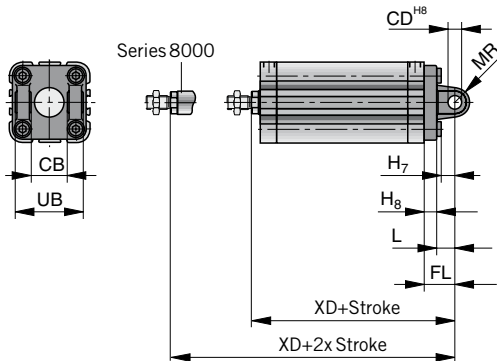

Material: cast aluminium

Dimension Table (mm) – Mounting B

Cyl. Ø	H ₇	H ₈	L	CB	ØCD ^{H8}	FL	MR	UB	XD+Hub (*)
32	10	10	12	26	10	22	9	45	73
40	13	10	15	28	12	25	11	52	77
50	12	11	16	32	12	27	12	60	80
63	17	11	21	40	16	32	15	70	89
80	16	15	21	50	16	36	16	90	100
100	20.5	16	25	60	20	41	20	110	118

Included in delivery: 1 rear trunnion mounting, 4 screws
 (*) Series NZ8000: XD + 2x Stroke

Dimensions for Mounting BAS

(Rear trunnion mounting with spherical bearing)

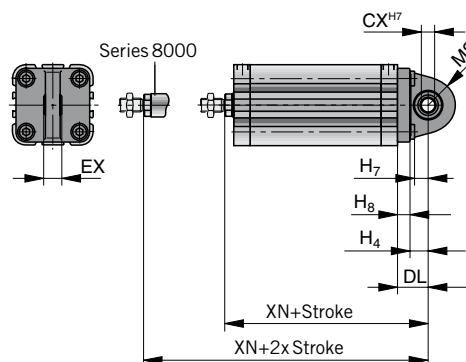

Material: cast aluminium

Dimension Table (mm) – Mounting BAS

Cyl. Ø	H ₄	H ₇	H ₈	ØCX ^{H7}	DL	MR	EX	XN+Hub (*)
32	12	10	10	10	22	18	14	73
40	15	13	10	12	25	21	16	77
50	16	12	11	12	27	23	16	80
63	21	17	11	16	32	27	21	89
80	21	16	15	16	36	29	21	100
100	25	20.5	16	20	41	34	25	118

Included in delivery: 1 rear trunnion mounting with spherical bearing, 4 screws
 (*) Series NZ8000: XN + 2x Stroke

Mountings – Series NZ...., Ø 32 – 100 mm

Dimensions for Mounting C

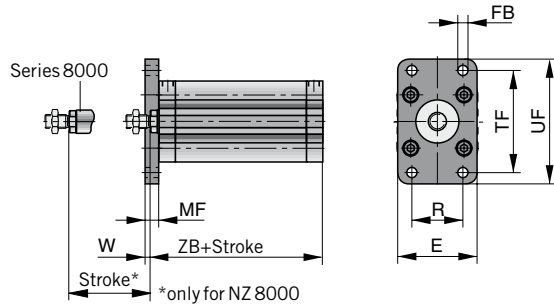

Material: cast aluminium

Dimension Table (mm) – for Mounting C

Cyl. Ø	ØFB	E	MF	R	TF	UF	W	ZB+Stroke
32	7	50	10	32	64	79	3	51
40	9	56	10	36	72	90	3	52
50	9	70	12	45	90	110	4	53
63	9	80	12	50	100	120	4	57
80	12	100	16	63	126	153	6	64
100	14	120	16	75	150	178	6	77

Included in delivery: 1 flange, 4 screws

Dimensions for Mounting D

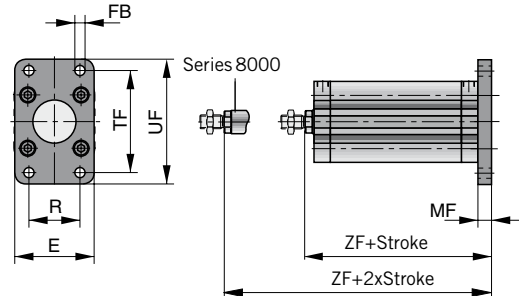

Material: cast aluminium

Dimension Table (mm) – for Mounting D

Cyl. Ø	ØFB	E	MF	R	TF	UF	ZF+Stroke (*)
32	7	50	10	32	64	79	61
40	9	56	10	36	72	90	62
50	9	70	12	45	90	110	65
63	9	80	12	50	100	120	69
80	12	100	16	63	126	153	80
100	14	120	16	75	150	178	93

Included in delivery: 1 flange, 4 screws

(*for Series NZ8000 : ZF+2 x Stroke

Mountings – Series NZD...., Ø 32 – 100 mm

Mounting A-..

(Foot mounting)

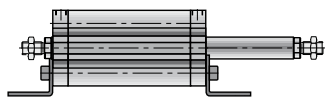

Mounting C-..

(Front flange mounting)

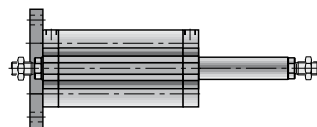

Mounting D-..

(Rear flange mounting)

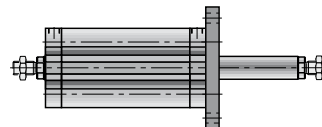

Accessories

Piston Rod Eye



Page 138

Piston Rod Clevis



Page 139

Compensating Coupling



Page 140

Coupling



Page 141

Magnetic Switch



Page 152

Adapter plate for Mounting



Page 145

Pivot for Mounting B



Page 142

Piston force and air consumption see page 9, order instructions see page 42, 43

**Dimensions – Basic Cylinder, non-rotating, Ø 32 – 100 mm
Series NZV....**

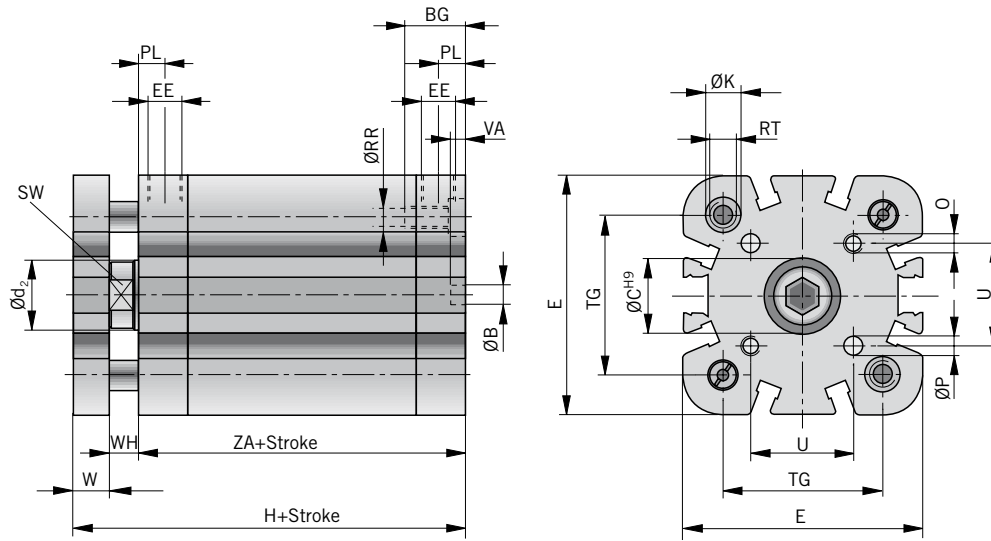

**Dimensions – Basic Cylinder, non-rotating, with through piston rod, Ø 32 – 100 mm
Series NZVD....**

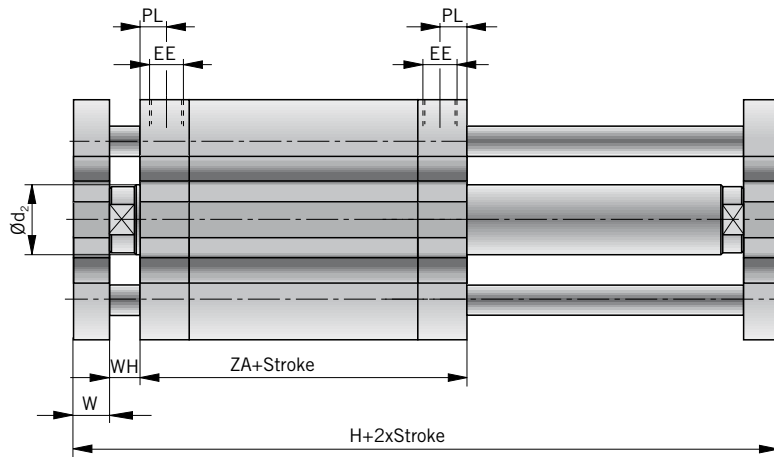

Dimension Table (mm) – Series NZV...., NZVD....

Cyl. Ø	ØB	ØC ^{H9}	Ød ₂ ^{H9}	E	H	H	ØK	O	ØP ^{H8}	U	W	BG	EE	PL	TG	ØRR	RT	SW	VA	WH	ZA
					+Stroke	+2x Stroke															+ Stroke
32	6	17	12	50	61	78	9	M5	5	19.8	10	14.5	G1/8	7.5	32.5	8.5	M6	10	4	7	44
40	6	17	16	58	62	79	9	M5	5	23.3	10	14.5	G1/8	7.5	38	8.5	M6	13	4	7	45
50	6	22	20	70	65	85	9	M6	6	29.7	12	14	G1/8	7.5	46.5	10.5	M8	17	4	8	45
63	8	22	20	80	69	89	9	M6	6	35.4	12	14.5	G1/8	7.5	56.5	10.5	M8	17	4	8	49
80	8	28	25	96	78	102	12	M8	8	46	14	15.5	G1/8	7.5	72	13.8	M10	19	4	10	54
100	8	30	25	116	91	115	12	M10	10	56.6	14	20	G1/8	10	89	13.8	M10	22	4	10	67

Piston force and air consumption see page 9, order instructions see page 42, 43

Mountings – Series NZV..., Ø 32 – 100 mm

Dimensions for Mounting B

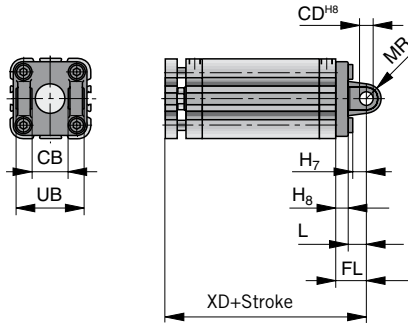

Material: cast aluminium

Dimension Table (mm) – for Mounting BA

Cyl. Ø	H ₇	H ₈	L	CB	ØCD ^{H8}	FL	MR	UB	XD +Stroke
32	10	10	12	26	10	22	9	45	83
40	13	10	15	28	12	25	11	52	87
50	12	11	16	32	12	27	12	60	92
63	17	11	21	40	16	32	15	70	101
80	16	15	21	50	16	36	16	90	114
100	20.5	16	25	60	20	41	20	110	132

Included in delivery: 1 rear trunnion mounting, 4 screws

Dimensions for Mounting BAS

(Rear trunnion mounting with spherical bearing)

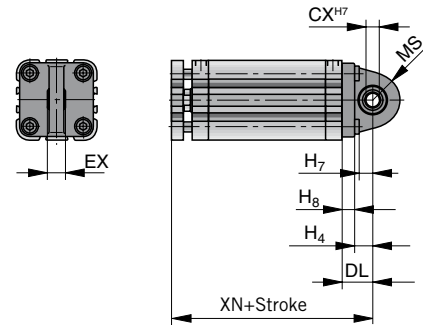

Material: cast aluminium

Dimension Table (mm) – for Mounting BAS

Cyl. Ø	H ₄	H ₇	H ₈	ØCX ^{H7}	DL	MS	EX	XN +Stroke
32	12	10	10	10	22	18	14	83
40	15	13	10	12	25	21	16	87
50	16	12	11	12	27	23	16	92
63	21	17	11	16	32	27	21	101
80	21	16	15	16	36	29	21	114
100	25	20.5	16	20	41	34	25	132

Included in delivery: 1 rear trunnion mounting with spherical bearing, 4 screws

Dimensions for Mounting BA

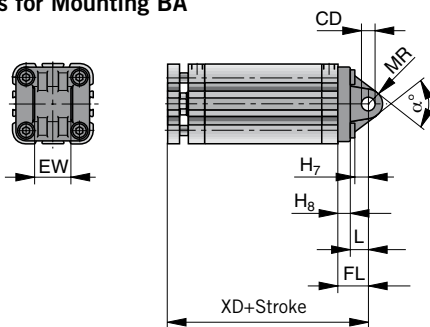

Material: cast aluminium

Dimension Table (mm) – for Mounting BA

Zyl. Ø	H ₇	H ₈	L	ØCD ^{H8}	EW	FL	MR	XD +Stroke	α°
32	11	10	12	10	26	22	10,5	83	60
40	14	10	15	12	28	25	13	87	60
50	15	11	16	12	32	27	13	92	70
63	20	11	21	16	40	32	17	101	60
80	20	15	21	16	50	36	17	114	70
100	24	16	25	20	60	41	21	132	70

Included in delivery: 1 rear trunnion mounting, 4 screws

Dimensions for Mounting D

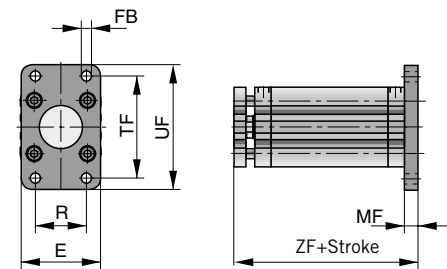

Material: cast aluminium

Dimension Table (mm) – for Mounting D

Zyl. Ø	E	R	ØFB	MF	TF	UF	ZF +Stroke
32	50	32	7	10	64	79	71
40	56	36	9	10	72	90	72
50	70	45	9	12	90	110	77
63	80	50	9	12	100	120	81
80	100	63	12	16	126	153	94
100	120	75	14	16	150	178	107

Included in delivery: 1 flange, 4 screws

* Note for piston rod version:
 In the configuration of a cylinder with through piston rod, Series NZD, the assumption is that both piston rods are identical. Only one is configured and this applies to both piston rods. If two different piston rods are required, a special cylinder must be ordered. Special cylinders are not configurable.

Order Instructions for Basic Cylinder Series NZ

Order-No. NZ 6 050 - 1000 / 000 - 0 0 0 0 0 X -13

Series	
NZ	Standard
NZD	with through piston rod*
NZV	with non-rotating piston rod
NZVD	with non-rotating through piston rod

External Thread Length of the Piston Rod (optional) *	
Length (2-digit) in mm Details see page 34	
-13	for example 13 mm

System	
6	Double acting without cushioning, for contactless position sensing
7	Single acting without cushioning, spring at front end, for contactless position sensing
8	Single acting without cushioning, spring at rear end, for contactless position sensing

Pneumatic cylinders for the Ex-Atmospheres (ATEX)	
X	See ATEX Certification 94/9/EG (ATEX 95)
0	Standard without Ex-Protection

Piston Rod Thread*	
0	External Thread
1	Special External Thread Details see page 34
2	Internal Thread (Standard)

Cylinder Diameter	
032	32 mm
040	40 mm
050	50 mm
063	63 mm
080	80 mm
100	100 mm

Piston Rod Material*	
0	Steel, high-alloy (Standard)
1	Steel, high-alloy (V2A)
3	Steel, unalloyed, hard-chrome plated (CK45)

Stroke Length	
Length (4-digit) in mm	

Piston Rod Extension*	
Length (3-digit) in mm	

Lubrication	
0	Grease (Standard)

Air connection	
0	Standard
1**	at one end in rear end cap
2**	at one end in front end cap

Seals / Wiper	
0	Standard (NBR)
1	Viton (+150°C)

Standard stroke length

Single acting version: 0005, 0010, 0015, 0020, 0025
 Double acting version: 0005, 0010, 0025, 0050, 0080, 0100, 0125, 0160, 0200, 0250, 0320, 0400, 0500 delivered preferably

** On request

Order Instructions for Cylinder Mountings

Description	Order-No.					
	Ø32	Ø40	Ø50	Ø63	Ø80	Ø100
Foot mounting A-..	PD 27917	PD 27918	PD 28072	PD 28073	PD 28074	PD 28075
Rear trunnion mounting B-..	PD 22704	PD 22705	PD 22706	PD 22707	PD 22708	PD 22709
Rear trunnion mounting BA-..	PD 23412	PD 23413	PD 23414	PD 23415	PD 23416	PD 23417
Rear trunnion mounting BAS-..	PD 23843	PD 23844	PD 23845	PD 23846	PD 23847	PD 23848
Front flange mounting C-..	PD 23403	PD 23404	PD 23405	PD 23406	PD 23407	PD 23408
Rear flange mounting D-..	PD 23403	PD 23404	PD 23405	PD 23406	PD 23407	PD 23408
Security bolt for mountings B,BA,BAS	KY 6153	KY 6154	KY 6157	KY 6156	KY 6158	KY 6159

Order Instructions:

For standard versions of basic cylinder, Series NZ, see price list (e.g. NZ6050-0080)

Ordering example for a configurable basic cylinder:

- Cylinder with through piston rod
- Double acting without cushioning
- For contactless position sensing
- Diameter 50 mm
- Stroke 80 mm
- Piston rod extension 15 mm (at both ends)
- Air connection at one end in rear end cap
- Viton seals (up to +150 °C)
- Standard lubrication
- Piston rod material, high alloy steel 1.4305
- Piston rod with external thread
- Without EX-protection
- External thread length of pistonrod 13 mm (at both ends)

Type designation per order code

NZ6050-0080/015-110100-13

Accessories

 Page 138	 Page 139	 Page 140	 Page 141	 Page 152	 Page 145	 Page 142		
---	---	---	---	---	--	---	--	--